

LIGHTLIFE

2

Seeing and Feeling Light
in Architecture and Design featuring projects from
Education and Science, Health and Care and
Art and Culture

Topic:
PERCEPTION



Richard Hall,
Marketing Director Zumtobel Lighting Division
about perception and collaborating with architects, designers and artists



Richard Hall next to a
light artwork installation by Maurizio Nanucci
(Photo: Markus Deutschmann)

PERCEPTION AND WORLDS OF EXPERIENCE

Perception is a highly individual and complex process which has a significant impact on our feelings and decisions. As a company too, we repeatedly ask ourselves the questions: How do you perceive us? How can we succeed in developing lighting solutions with you that offer you real added value in your projects? To achieve this, we look into the physiological and psychological impact of light on a daily basis. In the end, we want light to support the perception of your architecture after all.

A recent independent survey among more than 1,200 architects in Germany has shown that for them, Zumtobel is the strongest lighting brand. We consider this a confirmation of the fact that we have managed to communicate with you in the language of light, so that we can jointly create lighting solutions providing real added value. For this is what it is all about – offering the best results combined with the appropriate communication.

To achieve this, it is absolutely necessary to understand how light influences the perception of architecture. How can architecture be complemented by holistic light solutions, which suit your architectural expectations and enhance the experience of the users? To make this process of coming together as successful as possible, we try to speak in your language. Knowing the physiological effects of light and developing highly innovative luminaires and lighting control systems is our profession. However, what is equally important to us is to

communicate this knowledge to you, our customers, so that you appreciate the inherent value. For our aim is not only to develop and produce technically perfect luminaires, but also to find solutions for new challenges through networks and partnerships.

In order to be able to set ever new standards in this area, we have been collaborating for many years with a network of architects, interior designers, lighting designers and artists. Many innovations have been triggered through these international project partnerships. The joint development of project-related special solutions adjusted to individual requirements is just one important aspect when it comes to intensifying customer relations. We, too, benefit from the innovative power of you, our partners, and the way you use new technologies and creative means. Collaborations with artists like James Turrell, Keith Sonnier or Olafur Eliasson and architects like Jean Nouvel, David Chipperfield or Matteo Thun continuously push us to tackle the frontiers of the feasible. Using this creative power, together we succeed time and again in meeting our vision 'creating worlds of experience'. I would like to invite you to experience lighting solutions in the application areas of Art and Culture, Education and Science and Healthcare, as well as, learn more about new developments.

- 1 Editorial: Richard Hall,
Marketing Director Zumtobel Lighting Division
- 2 Contents

- 4 **PERCEPTION AND THE
MENTAL CONCEPT**
An interview with Prof. Christoph Schierz
and Peter Dehoff
by Kerstin Schitthelm

- 8 **DANISH RADIO CONCERT HALL**
Light plays first fiddle
by Burkhard Ehnes



- 18 **UNIVERSITY BUILDINGS IN WARWICK
AND ZLÍN**
Enjoying learning
by Mark Dudek



- 24 **THE MIDDLE AGES WERE NEVER GLOOMY**
The Making of Supersystem –
Interview with Max Hollein and Aysil Sari
by Christian Marquart



- 30 **TWO HOSPITALS IN HAMBURG**
Lighting for body and soul
by Andrea and Dr. Thies Boysen

- 38 **T-MOBILE SHOP IN VIENNA**
A new ambience at T-Mobile
by Wojciech Czaja

- 42 Comment: Beginning to see the light
by Riklef Rambow

- 44 News & Stories
- 48 Preview
- 49 Imprint, Project Team

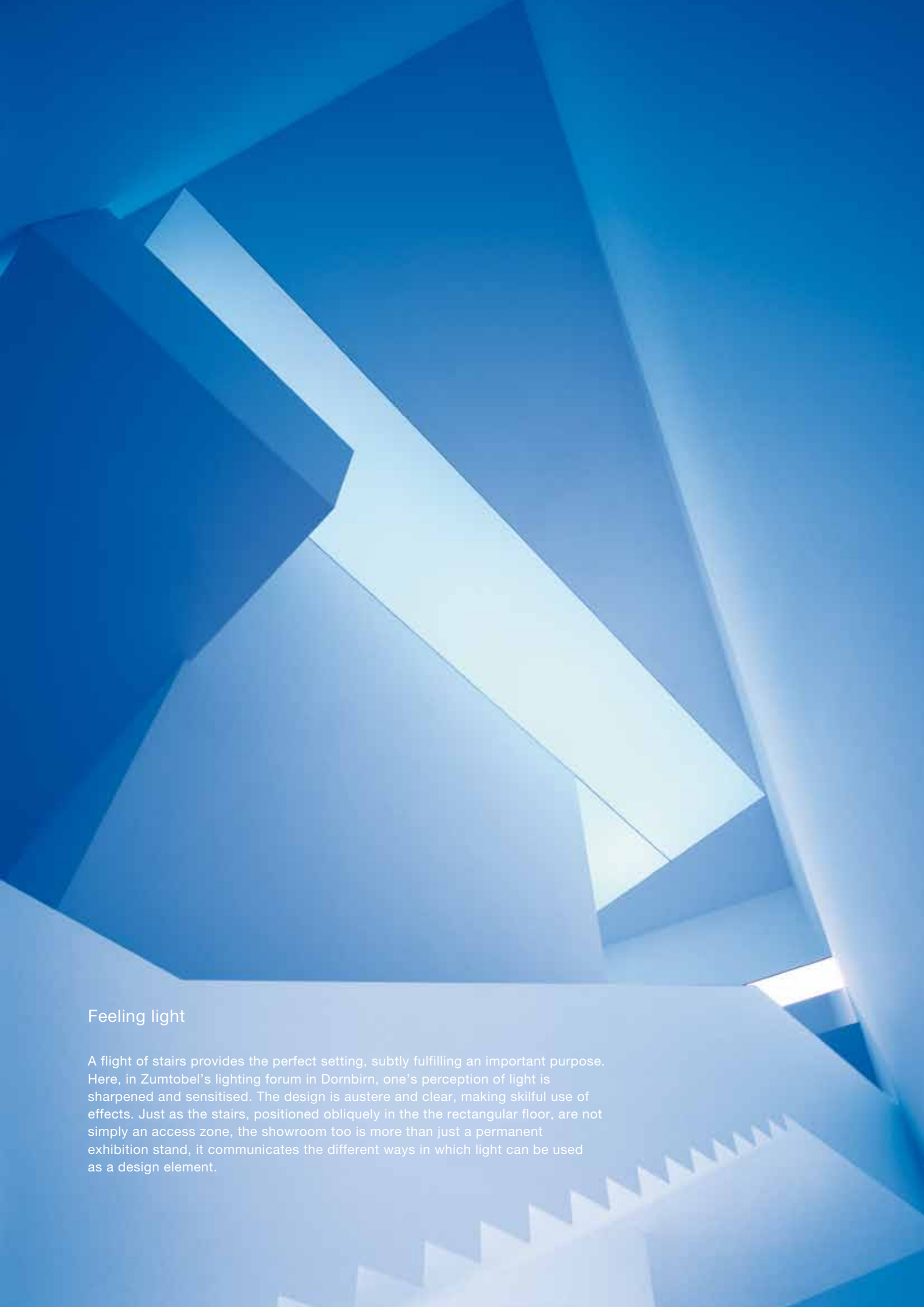

Feeling light

A flight of stairs provides the perfect setting, subtly fulfilling an important purpose. Here, in Zumtobel's lighting forum in Dornbirn, one's perception of light is sharpened and sensitised. The design is austere and clear, making skilful use of effects. Just as the stairs, positioned obliquely in the the rectangular floor, are not simply an access zone, the showroom too is more than just a permanent exhibition stand, it communicates the different ways in which light can be used as a design element.

PERCEPTION AND THE MENTAL CONCEPT

The work of the artist Jorinde Voigt opens up new perspectives on time and space. The often large-format drawings, which utilise perception, science and measurement for their content, seem like mental concepts which have been recorded and turned inside out.

Platonic DUAL I (I/1 + I/2)
(Acoustic Impulses, Flow, Trace)
Jorinde Voigt, Berlin 2008
Pencil, ballpoint pen on duplicator paper
Each 42 x 29.7 cm, unique copy



Professor Schierz of the Technical University of Ilmenau and Peter Dehoff of Zumtobel talk about perception

Prof. Schierz, you are an ergonomist, a physiologist and a lighting technologist. What do you understand by perception?

Christoph Schierz: Basically, from the huge volume of information with which we are bombarded, we only perceive what we want to perceive. There are things which affect our mood, and these in turn influence what we perceive. We tend to look at what is interesting, surprising or new to us rather than at everyday sights. This is pieced together with our previous visual experience to form a more complete picture of our surroundings, in which the lighting is also incorporated – a so-called mental concept. Conversely, the mental concept in turn determines what we perceive next.

How do architects think about perception? In a similar way to lighting technologist, or are there differences?

Christoph Schierz: There are quite clear differences. A lighting technologist tends to think from the outside in. An architect, in contrast, thinks outwards from his mental concept, he projects it more or less systematically outwards. When the architect starts to plan, he first has to develop these plans as ideas – on paper or using models. The lighting concept or the building only comes into being at the end. Lighting technologists, on the other hand, go into a building and measure the necessary lighting data or calculate these from the simulation. It's a quite different approach. This is also apparent when architects and lighting technologists talk together, when they often fail to understand one another. This can be attributed to the different mental concepts of architects and lighting technologists, which may not coincide in many areas.

Peter Dehoff: Yes, we lighting technologists have learnt to read figures, and we essentially derive our picture from the figures resulting from the calculation. For us, these calculated figures form the picture of the illuminated reality. We think in terms of illumination levels, luminous densities, glare limits, and use these to form a judgment regarding the solution for a certain room. This naturally leads to different conceptions than in the case of architects, who tend to see the room as a whole and consider the different surfaces and brightnesses and think in terms of the whole composition of the room.

You talk about the mental concept. Could you explain that?

Christoph Schierz: We have to bear in mind that we are not able to register our surroundings directly. We have eyes and we have sensory cells in the eyes which register the light, broken down into individual elements. Somehow we have to reassemble these individual elements again in our head and construct from these an internal picture of our surroundings. In this way, we believe that we are seeing our real surroundings, but in fact this is only a construction of our surroundings which we create for ourselves. This construction is the mental concept



Prof. Dr. Christoph Schierz is head of the Lighting Technology department at the Technical University of Ilmenau and is intensively concerned with the ways in which our perception is influenced. He is also an expert in the field of photobiology, for example circadian rhythms. It is believed that short-wave radiation in the blue light spectrum has a direct influence on people's internal clock and melatonin level and thus, among other things, on our activity, for example in the workplace. One important subject is the increasing requirements which apply to lighting for older people.

Peter Dehoff is involved in the strategic application of lighting at Zumtobel. He represents the company in numerous international organisations and researches trends in lighting technology in all fields of application and holds a lectureship in Light at the Technical University of Graz.

which we have of our surroundings. Our genes already roughly define this mental concept in advance. The mental concept then slowly develops after birth: we learn how to perceive our surroundings, we learn to distinguish distances, we learn to distinguish what is an object and what is simply the background of the object. These concepts, which are initially quite simply structured, are continually developed further during the course of our life. And basically an architect develops his mental concept in a different direction to a lighting technologist.

How does the mental concept help us in solving lighting problems?

Peter Dehoff: If, as lighting technologists, we take the mental concept into account in our planning and are aware that people respond in different ways to a lighting solution, then it's also helpful for us to consider the components of lighting in different ways. We like to make a distinction between three components, light for seeing, light for visual purposes and light for emotional function. More recently we have been talking about biological aspects of lighting which can have effects on health.

Christoph Schierz: Another important aspect of the mental concept is that lighting is used in quite different applications: if I'm lighting a high-bay warehouse, it needs to look different than if I'm lighting a shop. Everyone has a certain idea of how a shop should look, and the real shop also has to correspond to these ideas to some degree. At this point the mental concept is already formed to a certain extent and becomes complete, as soon as, one enters the high bay warehouse. The mental concepts then either fit together very well, or they do not. If they don't, then the viewer may perceive the result as a poor lighting solution.

Is it possible then to rate the quality of a lighting solution?

Christoph Schierz: One idea, for example, is the ELI (Ergonomic Lighting Indicator) concept, in which certain points are defined which can form a mental concept. The architect and lighting planner or lighting technologist can then communicate on this basis.

Peter Dehoff: The associated checklist contains an extensive range of questions. In order to make the result easy to understand, we have divided the checklist into five main categories of lighting. These comprise hard criteria such as visual function, but also flexibility, vitality, visual comfort and appearance. Each category has seven to eight sub-categories, together they make up the checklist. This categorisation makes it easier for us to draw up an evaluation of key aspects. These evaluations can then be represented in the form of a spider's web diagram, which makes it easy to show the result of the overall evaluation as an ELI diagram.

Does lighting for older people differ from lighting for younger people? Does it have to be, or should it be, different?

Christoph Schierz: They see things differently. In biological terms, the critical consideration is that in older people the eye is less light-transmissive. In principle, less light enters their eyes. This has fundamental consequences in terms of the biological effects of light within the human body. If older people don't get enough light, this can disrupt their daily rhythm. One can see this in old people's homes for example: providing more light makes it possible to introduce more structure into the daily routine. In view of the current discussion of energy issues, I'm concerned that the older population won't be provided with enough light in future.



“We have in fact found that the residents are more active during the day in the areas in which more light is available. This seems to do them good.”

Peter Dehoff

With consequences for the health of older people, such as depression, for example?

Christoph Schierz: Yes, that's probably true. One consequence, for example, would be sleeping problems, with the disadvantageous consequences these entail in terms of health. Of course this is true for all people, but this is all the more serious in the case of older people, who in any case receive less light through their eyes.

Peter Dehoff: At this point I would like to make mention of the research we have carried out at the St. Katharina old people's home in Vienna. There, we illuminate the day-room areas for older people with bright light, so that during the day they receive up to 2000 or even 3000 lux more light so that they can adjust to the natural daily rhythm, even though they spend all their time indoors. The theory is that residents should then be able to sleep better at night. We have in fact found that the residents are more active during the day in the areas in which more light is available. This seems to do them good.

Conglomerate – Study 16
(2 kiss, Eagle's Flight, March Time, 2 kiss
North, East, South, West)
Jorinde Voigt, Berlin, July 2007, 36 x 51 cm
Ink, pencil on paper, unique copy

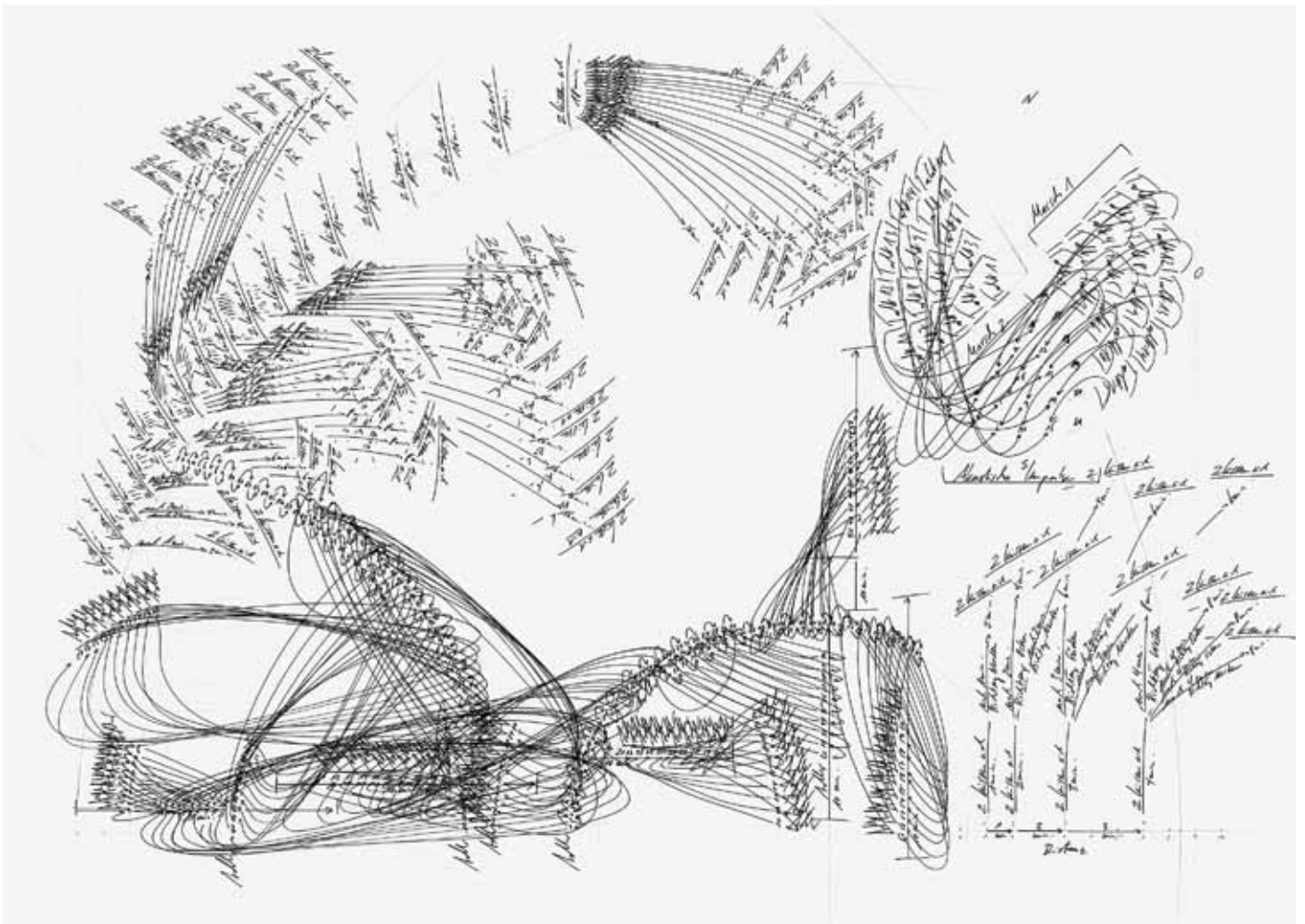

Client : Denmark Radio / Architecture: Ateliers Jean Nouvel, Paris/F

Light planning: Atelier Yann Kersalé, Paris/F

Photos: Torben Petersen (p. 8, p. 10–12, p. 13 top and bottom, p. 15 top), Ateliers Jean Nouvel (p. 9 top), Doris Kleilein/Bauwelt (p. 13 centre), Bjarne Bergius Hermansen/DR (p. 14, p. 16 left), Agnete Schlichtkrull/DR (p. 15 bottom), Philippe Ruault (p. 16 right) / Text: Burkhard Ehnes

DANISH RADIO CONCERT HALL

LIGHT
PLAYS
FIRST
FIDDLE



“You can only respond to the uncertainties of the future with the strength uncertainty provides: its mystery. (...) It must be a quantity that implies intimacy, a mysterious parallelogram that changes according to whether it is night or day. At night the space becomes a place for images, colours, and light: a manifestation of intense indoor life.”

Jean Nouvel



Flowing forms and subtle lighting moods give the large concert hall an almost magical appeal (large photo).
Composing in architecture and light:
Jean Nouvel (small photo).

The grand opening of the new concert building for Danish Radio took place in Copenhagen on 17 January. The design by Jean Nouvel incorporates four auditoria of differing sizes within a blue-clad cube, the façades of which serve as projection surfaces at night. With the Danish Radio Konzerthuset, Copenhagen and the international cultural world have acquired a symphony of contemporary architecture, innovative lighting and unique musical experiences.

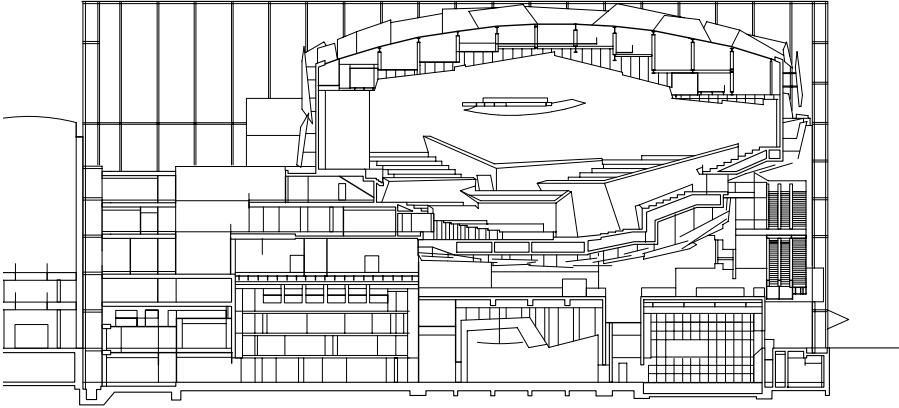

Section through the concert building on a scale of 1:1000 (top). Projections on the façade and the illumination of the foyer inside bring the cube to life at night (bottom).

The shell of Danish Radio's new "Konzerthuset" reflects the seasonal use of the building, as if this too were part of Pritzker Prize winner Jean Nouvel's architectural concept. During Scandinavia's bright summer months, when it is hardly used, it appears lethargically quiet from the outside, like a gigantic enclosure for the concert hall slumbering within. However, during its main period of use, during the twilight and night hours of the long winter months, the façade, 96 m long, 58 m wide and, at 45 m high, towering over its surroundings, comes to life. Unexpectedly, light starts to coruscate through the mysterious blue textile skin, creating a sophisticated setting for the diversity of musical life within. Key elements here are specially developed pillow like accent lighting, so called "concrete lights". The idea of light which seems to issue forth from the concrete itself, negating the very idea of hard concrete, exemplifies the sense of poetry and surprise inherent in virtually every detail of this synthesis of the different arts. The viewer finds the sheer number of such discoveries, the extraordinarily labyrinthine spaces and not least the virtuosity of the lighting moods created by Jean Nouvel's congenial partner of many years, the lighting poet Yann Kersalé, overwhelming and breathtaking. Quite quickly, instead of trying to analyse and comprehend the building, they just allow to unfold the effect for which it was conceived and for which it won an award: as a venue for the development, promotion and performance of all styles of music at the highest international level – and for the recording of this music for radio and television broadcasts by Danish Radio.





“Concrete lights“ in the foyer and corridors provide colourful accents to the concrete walls, the surfaces of which are finished in an “elephant skin” texture (top).

The starry sky in the entrance foyer, created from 1,600 LEDs, is a depiction of the night sky in the northern hemisphere as it was on 17 January 2009, the date of the ceremonial opening of the concert building (right).





In the foyer below the main hall, concrete lights, changing artistic gobo projections and zig-zag light lines create an unusually intensive space and light experience. The cloakroom furniture consists of instrument flight cases.

So this is, in effect, an immense music workshop, permanently vibrating with life, because even if no performance happens to be taking place in the large 1,800-seat concert hall (Studio 1), in one of the three smaller auditoria with 250–450 seats (Studios 2–4) or on one of the numerous “stages” in the extensive foyer, the foyer itself, which provides access to and connects the auditoria, remains permanently alive. This is ensured by means of projections of deliberately abstract images and embedded short video sequences with themes taken from the world of music, rendered in warm tones, which are projected onto the surfaces of the room. So that these projections can be created with the necessary intensity, Zumtobel had a particularly powerful gobo projector developed which was optimised to meet these requirements. As darkness falls, the surface of the façade, which had earlier watched calmly over the new and colourful suburb of Ørestad, is also brought to life through projections, this time primarily in mystical blue. The abstract motifs and video sequences convey an idea of what is happening behind the façade and invite the viewer to experience it. The idea of ‘Radio’ as a product, invisible in itself, is given a face; the building becomes a “magic lantern”.

Right at the bottom corner, this giant music cube is opened up for the visitor like a garage door. The visitor is welcomed beneath a representation of the starry Copenhagen sky as it was on the night of 17 January 2009, the date of the building’s grand opening by Queen Margrethe II. This scintillating firmament was created in collaboration with LEDON using 1,600 LEDs in a 300 m² perforated acoustic ceiling. Beyond the frosty starlight, the music venue opens up like a miniature city, with various terraces, large and small squares, bars and a restaurant. One can stroll through a spacious arcade with a restaurant above, past the three small auditoria and the offices, to Danish Radio’s other buildings, or one can turn off to the left and ascend the projecting staircase up to the large, all dominating central square, the main foyer, roofed with the shingles which encase the concert hall. Impressions of the world outside, the distant city and the weather are perceived as if through a filter.

The concrete wall lights and Korea standing luminaires are also used in the offices (right).

Studio 4 is designed for choral and chamber music (small photo at bottom). The “piano lights” specially manufactured for Studio 3 seem to float in space like individual piano keys (large photo at bottom).





The large hall holds 1800 visitors. To the left of the picture is the box used by the royal family, who were present at the inaugural concert by the Danish National Radio Symphony Orchestra.

If the pure and untreated concrete and wooden surfaces or even the multilayered quality or coarseness of the individual elements, have not yet impressed the visitor, the impermanent workshop atmosphere, by the time he reaches the cloakroom and the bar furnishings which seemingly consist of abandoned instrument cases, the effect is complete. At the same time, the liveliness conveyed by this staged transience allows the user a hitherto unimagined flexibility. The fact that the usual architectural references and rituals associated with such a venue have been wholly dispensed with such a relaxing effect awakens expectations with regard to the concert event. If this is taking place in the large concert hall, one first has to ascend via increasingly narrow stairs and increasingly low ceilinged corridors. Connecting passages lined with gathered orange felt, only sparsely lit at floor level, not only absorb all sound, but also screen out the last associations with the outside world and everyday life. Like a new world of its own, the concert hall then opens up, completely clad in warm wood tones, with its seats upholstered in various earthy hues. Here, architecture becomes a stage set, the space becomes a landscape. Like terraces suspended above a valley floor, the rows of seating are arranged around the stage, which is framed by mighty yet gentle mountains and deep valleys, with the organ enthroned above everything like a rocky outcrop. Everything is bathed in majestically subdued lighting, initially like that of the evening sun then, as the concert begins, like candlelight.

In fact, Jean Nouvel was inspired here by the autumn moods in the vineyards of "La Lavaux" on Lake Geneva. Accordingly, the Copenhagen concert hall is not, like the KKL concert hall in Lucerne also designed by Nouvel, clad like a wooden instrument, but with leaves, or "scales", reminiscent of a heap of autumn leaves, piled up against the surrounding façade as in a basket. The gala opening concert began with a specially commissioned composition by Andy Pape which made skilful use of the multilayered structure of this hall. Soloists and choirs in different registers sang from different balconies and from different depths within the room. The audience became part of the mise-en-scène.

The subtle lighting moods of the concert hall were made possible by a whole series of special solutions: a specially developed light fitting inset into the floor illuminates the walls of the balconies and floods them with soft light. Along the upper edge of the room, a lighting band simulates the entry of daylight, while at the same time it provides exactly the right lighting for the huge mural by Alain Bony and Henri Labiole which represents a stylised sunset. Indirect floodlights directed at the gigantic acoustic reflection sail in the centre of the room flood the hall with majestic halogen light. The desired lighting moods were composed from a total of over 800 individually controllable lights or lighting groups in the concert hall using the Luxmate lighting management system. The architect and user coordinated the lighting moods in advance using the Vivaldi interactive planning program, which proved very helpful in this respect. The necessary data had already been created during the planning phase using Inspirer visualisation software. The culmination of this work was a first virtual concert in a simulation of the concert hall at the Zumtobel presentation centre Terminal-V in Lauterach. The architects, planners, representatives of the user and the principal conductor applauded with eager anticipation.



Wall washers set into the floor provide safe and atmospheric lighting for the steps in the main hall (top).

The recessed floor lamps covered with frosted glass dramatically accentuate the wooden panelling of the concert hall (left). Detail drawing of the floor lamp (bottom).

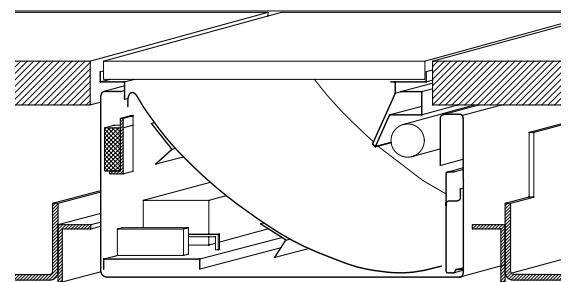

Whereas the large concert hall is dedicated to the great works of music, the three smaller auditoria provide a suitable ambience for all conceivable musical categories and niches – both visually, through three quite different design themes and acoustically, through adjustable acoustic reflection characteristics. One thing all four auditoria have in common is what is probably a uniquely high standard of technical equipment. This also accounted for a significant share of the construction costs totalling 226 million euro. This has made it the most expensive concert hall in the world, ahead of even the “Walt Disney Concert Hall” in Los Angeles designed by Frank O. Gehry. – Jean Nouvel: “Architecture is like music; it is made to move and delight us.”



Jean Nouvel at the grand opening of the Danish Radio Concert Hall on 17 January 2009, which was attended by numerous guests of honour from Denmark and abroad (top).

The large concert hall is composed like a landscape. Warm wood tones, rows of seats arranged like terraces and changing lighting moods turn a visit to a concert into a feast for the senses. The lighting is controlled by Luxmate Professional (right).



Lighting solution
CONCRETELIGHT light cushions, ZIG-ZAG light lines, built-in floor lights,
gobo projectors, ALW light fields, PIANO lights,
KAREA free-standing and wall-mounted luminaires, 2LIGHT mini-downlights,
PANOS downlights, LED starry sky with 1,600 LEDs,
emergency sign lighting, LUXMATE PROFESSIONAL





The cafeteria of the Tomáš Bata University Centre is equipped with Slotlight light lines (top).
The central concourse of the University Centre. Opened in 2008, the new building designed by architect Eva Jiříčková provides space for over 7,000 students and researchers on four floors (bottom).



University Centre Tomáš Bata / Client: Tomáš Bata University, Zlín/CZ
Architecture: AI Design s.r.o. and Eva Jiricna Architects, Prague/CZ
Warwick University New Digital Laboratory / Client: University of Warwick, Coventry/UK
Architecture: Edward Cullinan Architects, London/UK
Lighting design: Hoare Lea, Bristol/UK
Photos: Lubomír Ančinec (Zlín), Gavin Jackson (Warwick) / Text: Mark Dudek

UNIVERSITY BUILDINGS IN WARWICK AND ZLÍN

ENJOYING LEARNING!

Who wouldn't have wanted their school days to be like this? Motivating, inspiring, encouraging and, yes, challenging, set in a pleasant environment for the foundation of a life long learning process. Few of us have such positive memories of our school days – which is all the more reason why we wish this for our children.

For many years, educational buildings are the focus of our children's lives, and are also increasingly important as places of study and further education for adults. It is therefore crucially important to create an atmosphere which supports the learning and development process optimally. Architecture and interior design play a crucial part in configuring rooms in such a way that their different possible uses can be accommodated flexibly. Architecture and light, seeing and learning are closely related. Glare-free natural lighting, friendly colours, ergonomic furnishings and flexible lighting solutions help to create environments for motivated learning.

Example 1: University Centre Tomáš Bata, Zlín/CZ



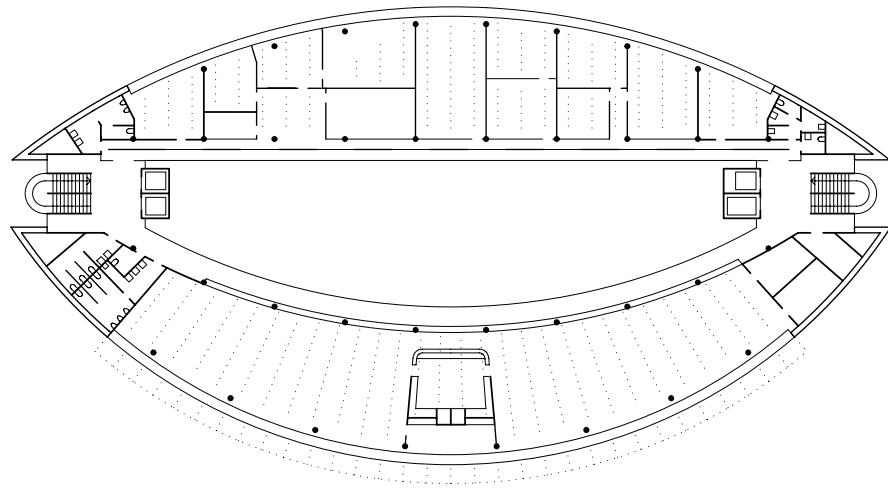

In school buildings in particular, the effective combination of natural and artificial illumination through intelligent control systems plays a decisive role. For example, the combined control of shading systems and artificial lighting significantly improves the quality of use and at the same time makes optimum use of energy-saving potential. The lighting in rooms used for educational purposes has to satisfy particular requirements. Since the layout of the desks is frequently flexible, the lighting must guarantee freedom from glare in any situation. Individual lighting options which can be controlled by means of intuitive control elements must be provided for the different areas and functions. The atmosphere of a room can be improved significantly through the use of light fixtures providing direct/indirect lighting. An educational building has a heterogeneous structure with areas which fulfil different functions: corridors and circulation areas require bright, friendly lighting for optimal orientation, whereas, breakout zones and canteens should stimulate communication and provide an atmosphere for relaxation.

These criteria have been optimally fulfilled in two new education and research buildings in the Czech Republic and in the UK – the University Centre at Tomáš Bata University in Zlín and The Digital Lab at the University of Warwick. In both projects, the architects have worked closely together with the lighting designers from the outset in order to create high-quality environments with comfortable lighting conditions for the users. One decisive factor in achieving the congenial atmosphere was that the great potential of lighting was recognised from the outset and exploited accordingly.

The ellipsoidal floor plan on a scale of 1:750 (top).
Glass-walled stairwell towers arranged at each end of the building lend the curved façades architectural solidity (bottom).





The Mirel II lighting system was used in the classrooms, ensuring absolutely uniform, glare-free illumination of the computer workstations.

The University Centre at Tomáš Bata University, Zlín, was recently opened by Eva Jiříčková, the architect, and Tomáš Bata Junior, son of the world famous philanthropic industrialist who provided so much support and inspiration for this institution and for the wider community of Zlín throughout the twentieth century. The new centre stands as a symbol of the town's investment in its people and their future; it is also a fitting tribute to Tomáš Bata's visionary ideals. The unusual segmented plan of the building comprises two crescent-shaped structures set side by side which contain the main reading and study rooms and archive areas. In between this is a spacious lit atrium providing an area for relaxation and informal meetings. The two grand curved facades are terminated at either end of their longitudinal axis by a pair of glass-walled stair towers which project above the building. The stairwells form the main vertical routes connecting the horizontal circulation galleries which run along both sides of the atrium, lending a clarity and rationality to the form of the building. This clear structure, typical of architect Eva Jiříčková, has the emphasis on functionality which is reflected in the lighting concept.

One basic architectural theme was that the clear lines of the building should be accentuated through equally clear light lines running through the rooms. For this reason the designers chose to use Slotlight and Claris II, an innovative luminaire with an understated geometrical formal language which is frequently used in educational buildings. In the central atrium, suspended Claris II luminaires are used as a continuous row lighting system with a total length of 54 m. They use direct and indirect light to emphasise the linear corridors and gallery ceilings. These in turn reflect the light downwards, creating a uniformly warm and diffuse lighting mood

throughout the atrium. Slotlight and Mirel II lighting systems were used in the other main areas to supplement the light reflected from the atrium. Mirel II grid lighting is combined to create architecturally strong light lines providing bright illumination in working areas and libraries. To accentuate the edges and lines along windows and surrounding areas, fluorescent tubes are recessed into ceilings and walls to enhance the complex sculptural forms of the architecture. Overall, the Tomáš Bata University is an ambitious project with a truly integrated architectural and lighting concept which emphasises the minimalist forms and spatial purity of the building's form.

The Digital Lab in Warwick, a building designed for research, education and the transfer of knowledge, is also distinguished by its integrated lighting concept. The new facility comprises over 5,000 m² of science related workspace arranged on four floors. Jointly funded by the university and the regional development agency, the facility currently specialises in the fields of virtual reality, e security, neuroimaging and experimental technology such as is used, for example, in the pharmaceutical sector. The architect Edward Cullinan's brief called for an adaptable spatial arrangement which could respond to the changing functional requirements within these relatively new disciplines. The rooms, with their widely varying lighting requirements, needed to provide a comfortable environment which could be illuminated in a consistent way at any time of the day or night, since the 120 or so researchers in the core team would be working round the clock. The designers therefore introduced daylight linking, controlled by Luxmate Professional – as twilight falls, the natural daylight is replaced gradually, and almost imperceptibly, by artificial lighting sources.

Example 2: Warwick University New Digital Laboratory, Warwick/UK





A view of the concourse of the Warwick Digital Lab (top and left). This is a place where the researchers can meet up and chat in an informal setting. The use of Tecton luminaires and Mellow Light contributes to the relaxed atmosphere.

The entrance to the Digital Lab, which was completed in 2008. The new building, which cost around 14 million euros, offers ideal working conditions for research teams from the fields of industrial manufacturing and healthcare (right).



The main entrance is accessed by way of a long gently sloping ramp. Once inside, one finds one's self in a high open concourse that runs the entire length of the building. It connects the working areas on the two floors above with the demonstration zones on the ground floor below. The 45°-angled ceiling is bathed in a soft coloured ceiling light. The generally homogenous appearance is created by the modular continuous row lighting system Tecton, which is equipped with "mellow light" optics. One advantage here is that the dimensions of the luminaires are reduced in comparison with the architectural surfaces, allowing balanced lighting which creates a bright and friendly atmosphere while allowing glare-free working. The unusual design of the building is particularly evident when viewed in cross section. Whereas most university buildings are aligned horizontally, with working cells branching off on either side of a central corridor, at the Digital Lab there is an equal relationship between horizontal and vertical directions of view and movement. Compartmentalised working areas on the second and third floors and spacious demonstration and display areas on the ground floor, with spaces for social interaction scattered informally between them, create optimal areas for all uses which are equipped according to specific lighting requirements. Professor Alan Chalmers, an expert in the field of visual perception, emphasised the important role played by the concourse as a social meeting point for the researchers, who frequently tend to avoid more formal social encounters: "Ideas usually spring from communication between the researchers – a key aspect which was taken into consideration in the conception of the building." The "mellow light" which illuminates the space in a natural and unobtrusive way, with the contrasts of light and shade characteristic of natural lighting, has a positive influence on this atmosphere.

The Tomáš Bata University and the Digital Lab are key examples of how lighting can be integrated in the design concept. Lighting plays an important role, whether in situations in which sustained concentration is necessary or in settings designed to encourage informal communication. The combination of different types of space within the building makes it even more important to have lighting which can be controlled simply and adapted to different learning situations. In both projects, the designers have managed to fulfil a wide range of functional requirements by means of an innovative lighting concept.

Lighting solution University Centre Tomáš Bata
CLARIS pendant luminaires, LANOS standing luminaires, ONLITE emergency light system, SLOTLIGHT light lines, MIREL grid lighting system

Warwick University New Digital Laboratory
LUXMATE PROFESSIONAL lighting management system, TECTON continuous row lighting system combined with MELLOW LIGHT



“A ,white cube‘ would not be the right environment here, it would suggest a quite different context. The creation of atmosphere through the use of colour contrasts greatly enhances the perception of the sculptures.“

Max Hollein

The sculpture collection at the Liebieghaus in Frankfurt offers an overview of the history of sculpture over 5,000 years, from ancient Egypt to Classicism. The works of art are elegantly displayed using the Supersystem LED lighting system.

THE MIDDLE AGES WERE NEVER GLOOMY



Light and the appreciation of art are inseparably linked. For any kind of museum, it is essential to create an appealing, differentiated lighting which allows the visitor an inspiring art experience and presents the exhibits in their best light. The sculpture collection at the Liebieghaus in Frankfurt was recently equipped with a specially developed lighting system.



The basic lighting of the different-coloured exhibition galleries is provided by means of light ceilings which create a daylight-like atmosphere. The individual exhibits are lit precisely by means of LED spotlights.

The Liebieghaus in Frankfurt is a sculpture museum which was recently equipped with the new Supersystem lighting system. Its innovative technology based on energy saving LED lighting fixtures made it possible, on the one hand, to significantly reduce the size of the luminaires used, while at the same time expanding its functional profile in terms of lighting design and control.

We spoke with Max Hollein who, as well as being in charge of the Liebieghaus sculpture collection in Frankfurt, is also Director of the Schirn Kunsthalle and the Städel Museum, and with Aysil Sari of Supersymetrics. The lighting designer and architect worked together with Zumtobel on the development of the multifunctional lighting system and played a lead role in the conception and implementation of the new lighting design in the Liebieghaus.



Some visitors race through the museum at a fast pace, while others like to take their time and engage more deeply with individual works. Did this mean you had to make compromises when it came to designing the lighting?

Max Hollein: The new lighting technology makes it possible to accommodate diverse objectives and interests. Naturally, lighting has the effect of creating a particular setting. We can use it to emphasise particular qualities of the works and accentuate the figures in the room. At the same time, however, it is possible to guide the viewer and direct their attention. The concerns of visitors with a specialist interest in the subject are also taken into account: the solution was to combine the room lighting with subtle LED spotlights. This has proved very successful. There is nothing worse than an exhibition space with a ceiling crammed with large, bulky spotlights which dazzle the viewer. The sculptures in the Liebieghaus are a collection which ranges from the Antique to Classicism, with the main emphasis on works of the Middle Ages. The play of light on a sculpture is very important to the way in which it is perceived. At the time they were originally created, for a particular purpose, they were often illuminated by very specific light sources, such as candlelight, or sunlight. We don't want the museum to have the atmosphere of an archive or depository, we want the sculptures to be displayed to their full advantage, both individually and as an ensemble.

This museum has distanced itself clearly from the "white cube" concept prevalent in other museums. What is the reason for this?

Max Hollein: The type of lighting one uses and the atmosphere one creates in a room does not necessarily depend on contemporary taste. Here, we are in a villa dating from the late 19th century. The classical style of this period made use of very rich colours; so in designing the interior of the rooms we deliberately opted for colours which generate contrasts, with the stone sculptures in particular. A "white cube" would not be the right environment here, it would suggest a quite different context. The creation of atmosphere through the use of colour contrasts greatly enhances the perception of the sculptures. The works from the Middle Ages, or those from Egypt, are mostly fragments of a greater whole. The colours refer to these other contexts and this is also supported through the lighting design.

“It’s difficult to communicate light. Documenting scenarios photographically doesn’t work either. You can’t just see light, you also need to feel it.”

Aysil Sari

Max Hollein

Viennese-born Max Hollein is director of the Schirn Kunsthalle in Frankfurt, which has been under his artistic and commercial direction since October 2001, and since January 2006 he has also been director of the Städel Museum and the Liebieghaus sculpture collection.

Under Max Hollein’s direction, the Liebieghaus sculpture collection underwent the biggest change to its infrastructure since 1990: the collection areas ranging from the Middle Ages to Classicism and the art of East Asia, as well as, the attic floor which has been converted into studioli rooms, have, since 2008, been given a completely new colour, light and communication concept. “Colourful Gods. The Colourfulness of Antique Sculptures” which was also opened in 2008 became the most successful exhibition in the history of the Liebieghaus.

Aysil Sari

After having spent some time in Mexico City, German-born architect Aysil Sari studied Marketing and also worked in this area. After moving to Austria, she joined Zumtobel in 2001 as a seminar leader, responsible for the training of employees and customers, with the main emphasis on architecture and light. In 2007 Aysil Sari settled in Switzerland, where she founded “supersymetrics”. The main areas of competence of this architecture and interior design studio are corporate architecture and lighting design, particularly for museums, as well as the development of lighting fixtures with the focus on LED technology.

Aysil Sari and Max Hollein being interviewed. Supersystem was specially developed for use in museums in intensive collaboration between the lighting designer and the director of the Liebieghaus together with the curators and architects.



It’s possible to enhance perception through lighting, lighting design, lighting policy. What does this involve, essentially?

Aysil Sari: The most important thing is the perception of the objects: sculptures in stone or wood, with or without preserved colour pigments. They need to be presented in a reasonable and attractive way without tiring the eyes or boring the public. As Herr Hollein mentioned: the play of the colours and the way they change rhythmically from room to room plays a very important part in this. The lighting has a supporting function; of course, principles of conservation also need to be taken into consideration here.

Does the interplay of daylight and controlled artificial lighting simply serve the purpose of creating a stable lighting situation? Or is the public intended to notice the way the natural lighting changes over the course of the day?

Aysil Sari: I wouldn’t go quite that far. The light in the rooms is intended to possess a certain dynamic quality. We have used two different lighting phases in the lighting ceilings, cooler and warmer light, which are mixed to reflect the character of the daylight currently entering the room. However, the spotlights which are pointed directly onto the objects are intended to keep the quality of the illumination and also the level of lighting constant.

The new lighting system also fulfils conservation requirements: the LEDs do not emit any radiation which might damage the exhibits, for example UV or infrared radiation.

Max Hollein: That is relevant in the case of the coloured sculptures in particular. However, another main concern was to reduce the amount of heat generated by the luminaires. This is why the solution which Frau Sari developed with Zumtobel was so important for us. In this old building we don’t have any 21st century climate-control technology with its enormous energy consumption. LED technology is ideal for us because it is surprisingly bright and precise, but at the same time it is very energy-efficient and consequently only gives off a small amount of heat. And because our conservationist approach extends to the historical appearance of the architecture of the Liebieghaus, it was also important to us to keep the light sources visually in the background, to have them virtually disappear. In this sense the lighting system creates its stunning effect almost covertly.



The lighting system, made of naturally anodised aluminium, is equipped with extremely small high-power LED spotlights which can be rotated by 360° and tilted by 90° to provide accentuated lighting. Cross section on scale 1 : 1

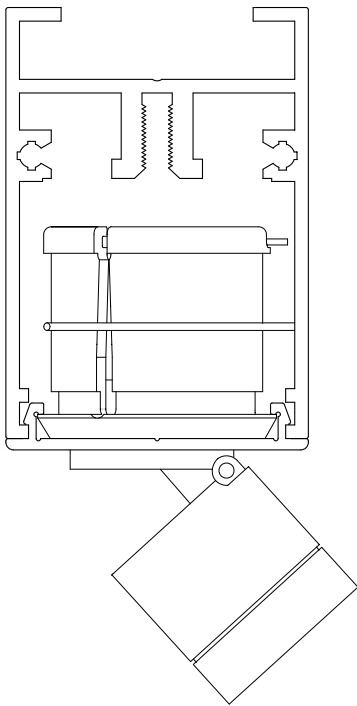

Supersystem

Supersystem is a multifunctional lighting system designed for complex lighting functions. In addition to achieving a minimised architectural design, the system was developed above all with the lighting effect created within the room in mind. Lighting solutions such as spotlights, wallwashers or direct/indirect components direct the light in a focussed and precise way and create an atmospheric ambience within the room. Moreover, the maximum reduction in form can be achieved with a minimum use of resources – this is made possible by the latest LED technology. The extremely compact and energy efficient high-powered LED spotlight is also suitable for providing accentuated illumination from greater distances. An object can be lit optimally from a height of 5 to 6 metres using only 2.5 watts per spotlight, as opposed to at least 50 watts in the past.

The UV- and IR-free light from the LED also guarantees protective illumination of sensitive exhibits. Recycled aluminium with a particularly positive energy balance is used both for the rail system and the spotlights.

Mrs Sari, as a lighting designer you have clear goals in mind when carrying out your planning and you have all the tricks of the trade at your disposal. Do you still have to improvise and experiment on site?

Aysil Sari: The aim was to apply a unified concept to the whole building and its exhibition spaces, not least through the use of lighting. We therefore needed a system which would fulfil its requirements in all areas of the building. This system does precisely that. However, the idea of working with LED spotlights in the museum is new. In this respect the use of the Zumtobel Supersystem here is a form of experiment. The important thing was that the curators of the Liebieghaus, director Max Hollein and the architects Kuehn Malvezzi were prepared to try out this experiment with us.

Max Hollein: The first thing we had to do was to find a common level of communication. The curators were at pains to formulate their requirements in such a way that Mrs Sari would be able to implement them. This didn't always succeed straight away. So experimentation became a mode of communication between all involved.

Aysil Sari: The subject of colour temperature in particular was important. Incidentally, I find the same thing in all projects – it's difficult to communicate light. Documenting scenarios photographically doesn't work either. You can't just see light, you also need to feel it. This is a problem encountered by designers as well as laymen. In order to find good lighting concepts for particular purposes it is useful to set up "models". Try it out and see how it looks: only then do you know.

What will the lighting of the future be like?

Aysil Sari: We are already working together with Zumtobel on the further development of the product. The plan is to optimise it in terms of attachments, that is to say everything relating to accessories, such as glare reduction, for example, the further optimisation of the colour of the light, the focusing of the light and also the power. Spotlights in the 2.5 watts range were used here, but in future we will also be going up to 5 and 10 watts. We aim to stick to the principle of miniaturisation. This is important in terms of resources. With the small LED spotlight used in the Supersystem we save 80 % in materials.

Even museums have to keep offering something new, present themselves in a new way. What part does the lighting design play in this?

Max Hollein: The reactions of visitors and the media to the new look of the Liebieghaus were interesting. They all spoke of seeing the sculptures in a completely new way – and they attributed this to the new lighting. In the past, nobody had talked about the lighting in the Liebieghaus, now they certainly do: because it has led to a new perception and appreciation of both the individual exhibits and the collection as a whole.

An unusual lighting and colour concept was realised when building the new emergency and surgery centre at the Marienkrankenhaus hospital in Hamburg. The colourfully gleaming façade has a cheerful and inviting appearance (bottom). Inside the building, the colours of the façade design are echoed in the corridors and wards (right).



Marienkrankenhaus:

Client: Otto Wulff Bauunternehmung GmbH & Co. KG, Hamburg/D

Architecture: Henke + Partner Architekten, Hamburg/D

Universitätsklinikum Hamburg-Eppendorf:

Client: Universitätsklinikum Hamburg-Eppendorf, Hamburg/D

Architecture: Nickl & Partner Architekten, Munich/D

Lighting planning: Ebert und Partner, Nuremberg/D

Photos: Andrea Flak, Nickl & Partner (p. 35 top) / Text: Andrea and Dr. Thies Boysen

TWO HOSPITALS IN HAMBURG

LIGHTING FOR BODY AND SOUL



Hardly any other area demands such complex lighting solutions as health-care and nursing, given that it is essential to create optimal conditions which need to fulfil an extremely wide range of requirements: doctors and care staff require different lighting situations in order to do their work properly, the most pleasant and stress-free atmosphere possible has to be created for the patients and healing processes can be effectively assisted through the specific use of lighting.

How to achieve cost savings while improving the quality of care – this is the economic contradiction currently faced by service providers in the health care sector. Those hospitals which know how to position themselves as service providers to the patient and at the same time learn to save costs in the right places are the ones most likely to solve this conundrum. Architecture and interior design can play a crucial part in achieving these two parameters. Architecture, through a design of the fabric of the building which conserves resources, is energy efficient and oriented around the organisational procedures, interior design through the use of varied surface textures and lighting and colour design which promotes recovery and responds to individual needs. Lighting, in particular, not only evokes moods and emotions, it has also been shown to influence the human biorhythm and even has a therapeutic effect: The deliberate use of both sunlight and artificial light in special clinically tested light therapies can relieve or even cure many acute illnesses and chronic complaints. Blue light helps relieve arthritis, red light stops migraines and new-borns suffering from jaundice are irradiated with short-wave light.



A lighting plan specifically oriented around the many requirements of everyday medical routine is therefore an indispensable element in innovative hospital concepts. Two current construction projects in Hamburg show that this can be achieved successfully, not only by private clinics offering cosmetic medicine, laser treatment or dentistry, but also, through a change of thinking, by public health care authorities. As highly innovative examples of this new approach, they serve as models for the kind of changes which are urgently needed within the health care sector.

In building its new emergency and surgery centre, the Marienkrankenhaus in Hamburg has embraced the idea that patients need to feel comfortable and well cared for – not only in the medical sense – and this is reflected in an unusual lighting and colour concept. The colourfully gleaming façade has an inviting appearance which also accompanies the patients into the interior of the building. With corridors and wards painted yellow, orange and red, the Marienkrankenhaus is one of the first hospitals in Germany to opt for a cheerful colour concept. Even in the operating theatres, one is surprised to find yellow ceilings and delicate wall decorations in warm tones. In order to fulfil the strict requirements in terms of hygiene and lighting quality, the lighting planners chose cleanroom lighting fixtures with three switchable illumination levels which allow them to react flexibly to different treatment situations. In addition to the clinical lighting in the intensive care unit, the cove lighting with dimmable light fixtures on the ceilings is unusual, but extremely pleasant. “The ceiling, as a fifth wall, is designed to be lightly structured and coloured in order to create a pleasant ambience without any glare for patients confined to bed” explains architect Dino Henke. The effect of such flexible lighting concepts can also be seen in the wards: the linear Pureline lighting and medical supply unit combines indirect room light and direct reading light to provide comfortable yet medically safe illumination for all requirements.

Yellow, orange and red – the planners also opted for a lively colour concept when designing the wards. The linear Pureline lighting and medical supply unit provides both pleasant indirect room lighting and direct reading light (left).

Even the operating theatres have surprisingly colourful wall designs. The strict requirements in terms of hygiene and lighting quality are fulfilled by means of cleanroom lighting fixtures with three switchable illumination levels which allow them to be adjusted flexibly to different treatment situations (bottom).



Example 1: Marienkrankenhaus, Hamburg/D

Even more revolutionary in terms of hospital architecture is the design of the recently opened Uniklinikum in Hamburg-Eppendorf (UKE) designed by Munich architects Prof. Hans Nickl and Prof. Christine Nickl-Weller. The Medical Director, Jörg Felix Debatin, speaks of a “new clarity”. The building accommodates 16 operating theatres together with intensive care facilities and over 700 beds. All support facilities and specialist departments are arranged so that staff and patients only have to travel short distances, which facilitates the treatment of related illnesses.

The new UKE defines the term “modern” in a much more complex sense and in terms of the change in approach described above: the UKE is the most modern hospital in Europe. When planning the new building, the main priority was that, firstly, the staff should be able to work cost effectively, while at the same providing the highest quality of care, and secondly, the patient was seen as a “client” and an individual, whose recovery is the result not only of good medical care but also of an atmosphere in which the patient feels secure, comfortable and well cared for.

The new Uniklinikum in Hamburg-Eppendorf accommodates 16 operating theatres and over 700 beds. Nonetheless, the clever arrangement of the structure around several atriums means that staff and patients only have to travel short distances and can easily find their way around (floor plan of standard floor, scale 1:2000).

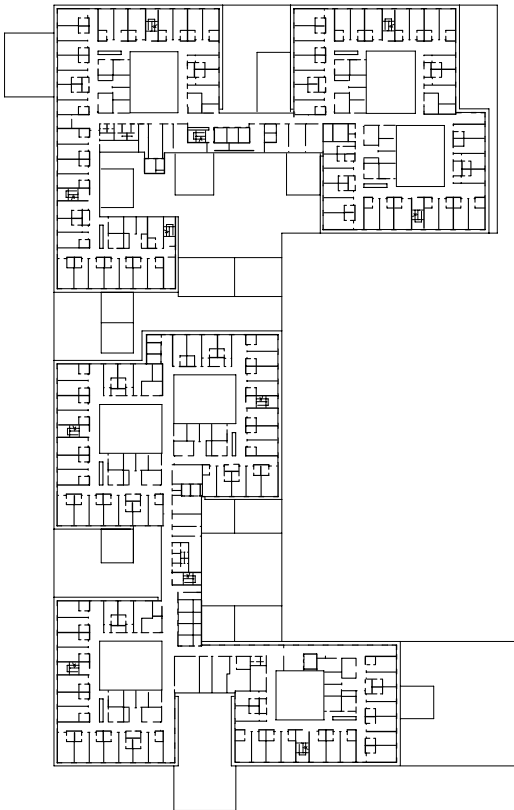

Example 2: Universitätsklinikum Hamburg-Eppendorf/D

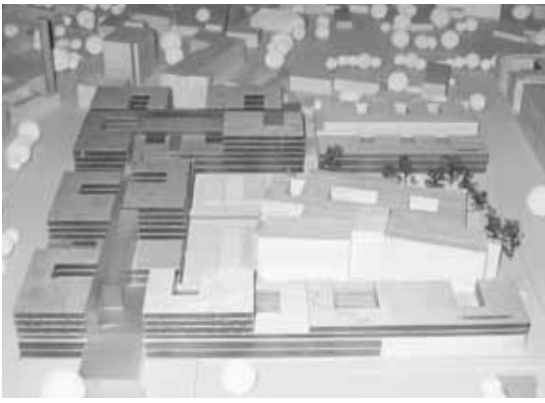

The model by the Munich architects Prof. Hans Nickl and Prof. Christine Nickl-Weller shows the gigantic dimensions of the new hospital building (top). The large entrance foyer of the modern new hospital is bright, clearly structured and flooded with light (bottom).



In Eppendorf, the aim was to largely avoid the atmosphere of the typical hospital environment. For example, on the 2nd floor there is the 'hospital boulevard' which, with its library, hairdressers, restaurant and shops, is intended to make the patients' stay in hospital more pleasant (bottom).



The efficient organisation of the running of the hospital takes place behind the scenes – largely invisible to patients and visitors. This assists the recovery process, as does the very comfortable design of the wards.

The “accommodation” offered to patients in the UKE more closely resembles a hotel room than a cell. The wards are painted in warm colours and have dark parquet floors. Each bed is equipped with its own multimedia unit which allows the patients to watch TV, make phone calls or surf the internet independently of patients in adjacent beds – all using headphones of course. The Conboard media supply panel developed in collaboration between the architects and the UKE, with its connections for high voltage power supply, gas supply and communications technology, was integrated in a high quality cabinet system.



Bright colours dominate the reception areas of the individual wards. The reception desks are reminiscent of the reception of a modern hotel, and welcome the patient like a guest (left).

The patients' rooms, too, are given a home-like character through the warm colour scheme, dark parquet flooring and innovative lighting control technology. The Conboard media supply panel, which houses all the necessary technical connections, is a comfortable and aesthetic solution (right).

The innovative lighting control technology of the bed lamps with separately switchable components for room light, reading light and LED orientation ensures a contemporary and aesthetic lighting ambience in the wards. This solution avoids the usual problem of having the technical connections both visible and close to the patients and thus reduces the alienating effect of a hospital environment.

The hospital boulevard on the second floor should also be seen in this light. With its patients' library, cafeteria, restaurant, shops, hairdressers, internet facilities and a branch of the Hamburger Sparkasse bank, it makes a stay in hospital much less tedious. In these areas, the main priority of the lighting planners was uncomplicated orientation. They chose light fixtures with a contemporary linear form which provide pleasant lighting and create a homogeneous appearance. This too is part of the requirements profile for a modern hospital. The UKE is one of the first hospitals in which the patient doesn't have the feeling of leaving the outside world behind when they pass through the main entrance. In the subjective experience of the patient, a hospital must have an inhomogeneous structure similar to that with which they are familiar in everyday life and must be perceived as being a living place: it must offer public and less public areas, times of day must remain recognisable and the individual needs of the patients must be taken into consideration as much as possible. The two Hamburg hospitals exemplify the change in thinking which is taking place within the health care market. An exciting challenge for architects and planners with great potential for the building industry.

Lighting solution Marienkrankenhaus

CLEAN ADVANCED, CLEAN SUPREME, CLEAN BASIC cleanroom luminaire, PURELINE lighting and medical supply system, TECTON-TETRIS continuous row lighting system, PANOS downlights

Lighting solution Universitätsklinikum Hamburg-Eppendorf

SLOTLIGHT recessed luminaires, TECTON continuous row lighting system, PANOS downlights, CONBOARD medical supply system (special solution), PERLUCE closed lighting system, ONLITE emergency sign lighting, CLEAN cleanroom luminaire, CLARIS pendant luminaire



Client: T-Mobile, Vienna/A
Concept: cdplan, Goldenstedt/D, Interbrand, Zurich/CH
Interior design: cdplan, Goldenstedt/D
Lighting planning: Vedder Lichtmanagement, Munich/D
Electrical installation: Siemens Gebäudemanagement & -services GmbH, Vienna/A
Photos: Bruno Klomfar / Text: Wojciech Czaja

T-MOBILE SHOP IN VIENNA

A NEW AMBIENCE AT T-MOBILE



Meeting between customer and sales adviser. Customers with more detailed questions can retire to one of the two advice booths. High backrests ensure the necessary privacy. A touch-screen built into the table surface allows customers to leaf through the virtual catalogue.

The telecommunications service provider with the magenta-coloured T recently opened a new branch in Vienna. The pilot shop, one of a total of eight throughout Europe, features a specially-developed shopfitting concept. Fewer barriers, more technology and an interplay of light and shade.

The density of mobile phone ownership in Austria is among the highest in Europe. So how does a company set itself apart from the competition and win new customers despite this oversupply? "Nowadays, it's no longer possible to achieve a lead with hardware alone", says Lars Bolle, Vice President, European Sales Marketing at T-Mobile International. "Most products are more or less the same and apart from the contracts, hardly differ from one another any longer." What makes T-Mobile stand out? Software, service, customer friendliness.

The German architectural practice cdplan, together with Interbrand from Zurich, emerged as competition winners with the intention of translating these notional concepts into material form. "Our primary goal was to make consultations and sales conversations more comfortable", explains Managing Director Ulrike Warnking. "With the new fixtures and fittings, we have managed to overcome the barrier effect of the conventional shop fit-out." The pilot concept involves individual counter units positioned in the centre of the room and special consulting areas like the high-backed discussion booths or the seating cube in the window display, all in white. However, where concentration is important, the atmosphere becomes more relaxed, the bright surfaces give way to wood veneer and sand coloured velour.

Touchscreens embedded in the desktops and counters allow a multimedia-based dialogue between customer and salesperson. Multitouch technology makes it possible to compare products, tariffs and different service packages. The idea behind this is persuasive: instead of using catalogues and brochures, the salesperson presents the options to the customer digitally, as, after all, these services and products on offer are also digital.



“Two of the main goals which we wish to achieve with the reorientation of the shop concept are more emotion and differentiation in terms of the communications solutions we offer – lighting and lighting moods are essential components here. The innovative lighting concept and the use of the latest technology help us achieve the greatest possible degree of differentiation from our competitors.”

Lars Bolle, Vice President European Sales Marketing at T-Mobile International

The first of a total of eight pilot projects has been opened in Vienna. Further shops are planned for Lübeck, Dessau, Hof, Frankfurt, Amsterdam, Nottingham and Prague. The first thing you notice when entering the new world of T-Mobile is that the whole branch on the ground floor of the imposing T-Center (Architektur Consult, Günther Domenig and Hermann Eisenköck, completed in 2004) is suffused with the corporate colour of the company. The magenta appears more intense because the level of the lighting in the surrounding space has been toned down. “This was a conscious decision - it reinforces the brand identity and creates an exciting contrast with the white presentation and consulting areas” says Munich lighting planner Reinhard Vedder. However, the key factor is not the colour itself, but the dramatic way in which it is presented. Whereas, in the past, shops have usually been lit with uniform brightness, creating little atmosphere, in Vienna a concept involving specifically focused lighting has been realised. Where light is needed in order to illuminate a work surface, a consulting area or a product, intensive lighting is provided, whereas, in the rest of the space it remains subdued in order to create a lively contrast effect. The most difficult part involved the lighting of the various screens and computer monitors. Detailed planning made it possible to avoid reflections on the surfaces so that the information displayed remains easily legible.

The alternating use of diffuse lighting and focused spotlights supports the language of the architecture, creating a more relaxed overall shop design. The rectangular recessed downlights from the 2Light series are mounted in the ceiling in a regular pattern. Only the reflector inside the lighting head decides whether, when it ends its journey, the beam of light illuminates a mobile phone or a salesperson’s hand. In addition, the Vivo spotlight, often used for display purposes, and Resclite emergency lighting were also used. LEDs, precise and pin-point accurate, were used above the consultation desks, as well as, in the acoustically insulated seating cube.



The different stages of advice, consideration and purchase. While the white standing desks are used to provide sales advice, the customer can retire to the couch to consider their options. This is where the idea of a living room atmosphere comes into its own.



The advice cube is a hybrid of private and public space. Even though the customer is virtually sitting in the shop window, they can surf through the menu at their leisure. Different information views can be displayed side by side on the multitouch screen set into the table surface.

The wall lights in the advice cube were developed based on the Floodline LED light line.
Front view, top view and side view on a scale of 1:10

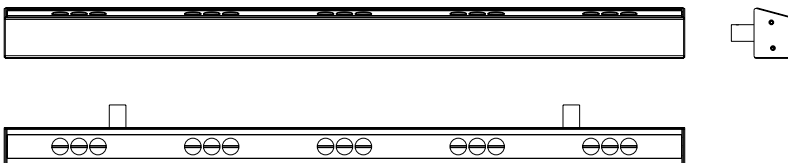

“I believe that this is a shop concept with great potential for the future”, says lighting planner Vedder. “On the one hand, the customers feel at ease and comfortable, almost as if they were in their own living room, on the other hand, we save a lot of power through the focused lighting” – as the energy balance shows: between 35 and 50 W per m² are required in conventional shopfitting. With an output of 15 to 20 W per m², this concept allows savings of over 50 % in energy costs. Intelligent lighting planning which makes also economic sense.

Lighting solution

2LIGHT downlights, VIVO spotlight system, LED special solution, OREA waveguide pendant luminaires, PANOS downlights, MICROS NV downlights, 2LIGHT downlight system special solution with ONLITE RESCLITE



Beginning to see the light – A comment by Riklef Rambow

Photo: Hélène Binet

Good architecture enriches and enhances our lives. Sometimes, good architecture can even make us happy. We know quite a lot about how it does this, but by no means everything. It has to do with the creation of spatial situations which are harmonious in every respect. Situations in which light, colour, materials, proportion and details interact in such a way that they fully satisfy or, better still, surpass our expectations and needs. You can call this atmosphere, or try to express it in other terms. In any case this involves a particular form of integrated perception which is experienced using all the senses and, as well as, permitting effective use, also provides pleasure.

However, thinking about what constitutes good architecture soon leads to an apparent paradox. On the one hand, we believe that truly successful spatial creations act on such a fundamental psychological level that one is inclined to speak of a type of anthropological constant: nobody can remain unmoved by good architecture. On the other hand, empirical observation shows that this is not the case. The perception and evaluation of architecture depends to a great degree on the attitude which a person brings with them into the situation. Even multiple award winning masterpieces of atmospheric architecture like the new “Kolumba” diocesan museum in Cologne designed by Peter Zumthor leave some visitors cold. What one person sees as perfect lighting and an ascetic material aesthetic which presents the works of art to their best advantage, is to someone else a spartan, poorly-illuminated box. Without the readiness to embrace a particular form of perception and without the ability to “read” the space, no effect will be felt and no pleasure derived from the architecture.

Consequently, even something as apparently elementary as perception has to be learnt. The fact that we take for granted the way we are always surrounded by space and architecture does not mean that their perception is not sub-

ject to preconditions. This can be illustrated particularly well with reference to light, as one of the most important design elements in architecture. Of course, anyone who possesses the physiological prerequisites for doing so can perceive light and may sense when it is too bright or too dark for certain activities. Warm and cold are also concepts which can be applied with a very high level of consensus. Beyond these quite fundamental assessments, most of us lack the terms to describe differentiated qualities of the atmosphere created by light. It is therefore difficult to communicate these ideas, not just with others, but also with ourselves.

Why do we need a vocabulary to distinguish and describe lighting situations? Aren't there enough experts who can analyse and explain light from a physiological, technical, ergonomic, architectural, poetic or art-historical perspective and who make sure that we are provided with the conditions which we require? It's not quite that simple. I'm not just talking about perception in a passive sense, the simple response to existing stimuli, I mean an active perception capable of taking in the diversity of natural and artificial lighting situations and deriving pleasure from this diversity and its continuous change. An active perception which has penetrated the interplay of subjective sensation and objectivisable parameters to the extent that we not only comprehend creative decisions, to a certain extent we can make these ourselves. We do this every day in offices, in schools or in our own homes.

The fascinating interdisciplinary subject of light should be taught in schools as part of the interdisciplinary subject of architecture. Not as an ideologically influenced “training in good taste”, but as a knowledge-based development of perceptive ability which “opens the eyes” and generates an enthusiasm for discovering new facets of light and architecture every day.

Riklef Rambow, born in 1964, studied psychology and obtained his doctorate with a thesis on “Communication between Experts and Laypersons in the Field of Architecture”. Having carried out scientific research at the universities of Frankfurt/Main and Münster he has, since 2001, been working at the Brandenburg University of Technology in Cottbus, currently as visiting professor for Architectural Communication. He also runs the architectural and environmental psychology consultancy PSY:PLAN in Berlin.

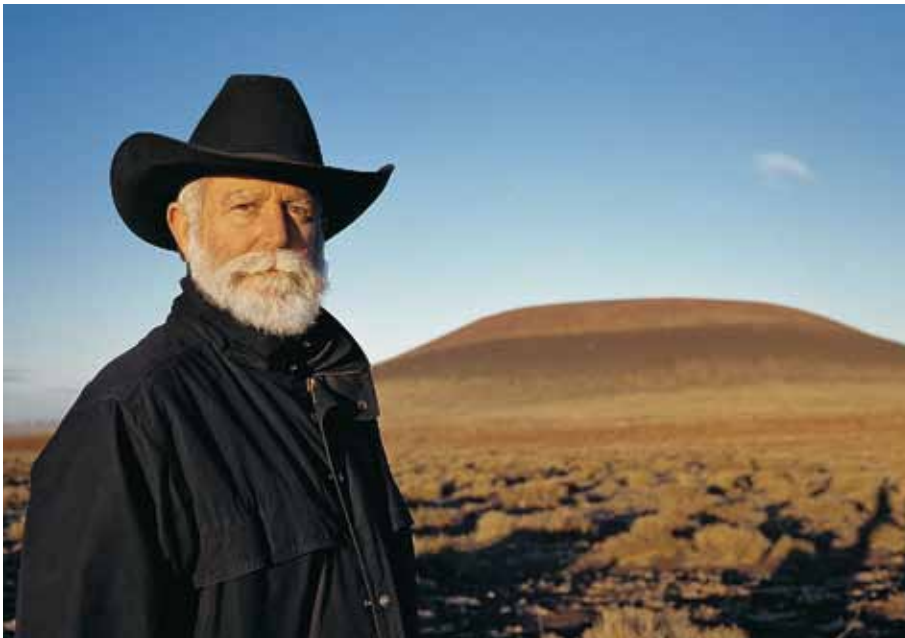

JAMES TURRELL AT THE CENTRE FOR INTERNATIONAL LIGHT ART IN UNNA

Although light art has now become established as an independent art form, it is still a comparatively young discipline. The only museum devoted exclusively to this subject is the Centre for International Light Art in Unna. Since 2001, the Centre, located ten metres underground in the former cooling vaults of the Lindenbrauerei brewery, has been showing works by well-known representatives of the genre such as Olafur Eliasson, Mischa Kuball, Mario Merz and Keith Sonnier

James Turrell is one of the best-known contemporary light artists (top). The Centre for International Light Art in Unna is currently showing the "Geometry of Light" exhibition, which includes new and rarely-exhibited works by the artist (bottom). Provided on loan by Zumtobel.

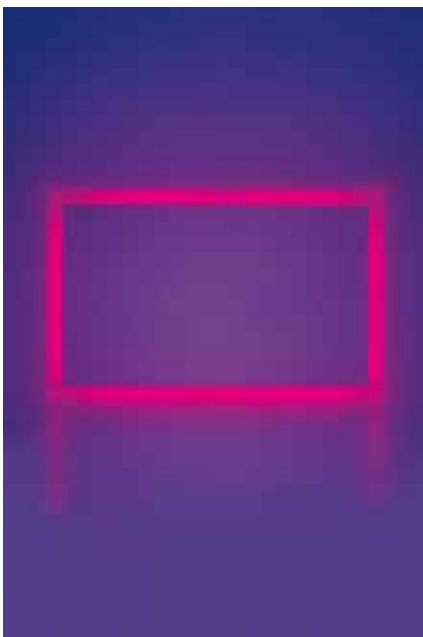

in its permanent exhibition. Since 1 February the collection has been augmented by the first outdoor installation in Germany by James Turrell, one of the best-known contemporary light artists. To coincide with the unveiling of "Third Breath, 2005", until 31 May the Centre is staging the extensive exhibition "Geometry of Light", which includes, in particular, new and rarely-exhibited works by the American artist.

Since the 1960s, James Turrell, now 65 years old, has devoted himself entirely to the medium of light. In Turrell's light objects, which can be seen in museums all around the world, light appears as a space-creating substance which one can enter and participate in visually. His installations are not illuminated in the classic sense. For instance, they contain no shadows – the only spatial object is the light. Turrell plays with perception in that he stages a spectacular interplay of nature, light and colour in space-light artworks.

The sky also appears repeatedly as the subject of his works. For example, he is known, not least, as the inventor of the "skyspaces" which have become a sort of trademark over the course of the years.

The touring exhibition "Geometry of Light", offers a comprehensive insight into the artist's work. In particular, it refers to Turrell's life work, which is closely related to the concept of the Skyspace: "Roden Crater", the extinct volcano in Arizona. Since 1974, Turrell has been shaping the circular cone into an observatory in which visitors can experience the sky with all its phenomena in a new way. In addition to photographs of the site, the exhibition in Unna also presents a large-scale model of the Roden Crater, at the foot of which the remains of a Hopi Indian

settlement can be found. An interactive animated model of the Roden Crater gives the viewer an insight into the inner world of the crater, allowing them to experience its dimensions and individual viewing chambers. Also on display, on loan by Zumtobel, is one of the artist's most recent works. This large-format light picture from the "Tall Glasses" series consists of glass and focuses the effect of light on a surface in the room. To create this, Turrell worked with engineers from Zumtobel to develop a specific programming for LEDs which generate gentle movements of light and colour on the image plane. The technology of James Turrell's "Floater 99" lightspace, which has been on exhibition in Unna for five years, is also on permanent loan from Zumtobel. "Floater 99" is a space filled with a kind of light fog, a light picture illuminated from within itself, without picture frame or wall fixings.

www.lichtkunst-unna.de

The museum is located ten metres underground in the former cooling vaults of the Lindenbrauerei brewery (small picture at bottom). An interactive model of the Roden Crater offers views of the artwork's viewing chambers (large picture at bottom). Photos: Florian Holzherr



FOUR iF PRODUCT DESIGN AWARDS

For more than 50 years, the iF design award has been known worldwide as a hallmark for design and innovation. It is one of the three most important design awards in the world. With its 16 categories, the international competition is aimed at entrepreneurs, designers and manufacturers who are committed to good design and display a particular spirit of innovation. This year, 2,808 products by 1,025 competition participants from 39 countries were entered for the prestigious award. In the end, 802 of these received the coveted award, including four Zumtobel products.

The **Aero II Hybrid** office pendant luminaire, which was presented in detail in the last issue of *Lightlife*, combines inorganic LEDs for a brilliant direct lighting component and fluorescent lamps for indirect general lighting. This hybrid concept designed by Sottsass Associati of Milan makes it possible to significantly increase the overall efficiency of the luminaire system in comparison with conventional fluorescent light fixtures. With its extra-slim body, only 30mm wide, the **Linaria Seamless** individual light line is the ideal luminaire for applications with aspirational standards. The luminaires can be lined up to create continuous light lines of uniform brightness. With its hybrid technology, the **Supersystem** multifunctional lighting system allows complex lighting solutions to be realised in a design which is reduced, in formal terms, to the function. The design by Supersymetrics combines a resource-conserving use of materials with lighting comfort of outstanding quality.

The **Zbox** lighting control system is uncomplicated yet versatile. Thanks to its simplicity of operation, intuitively understandable key symbols and LED status display, it allows hotel guests to easily select the right lighting moods and brightness levels. Additional lighting moods for the night-time with greatly reduced brightness levels create a pleasant atmosphere and make optimum use of energy-saving potential. All the winners will be present at the annual iF design exhibition, which can be seen from March to August 2009 in Hanover. The awards ceremony for the 50th iF gold awards took place on 3 March 2009 at the CEBIT in Hanover.

www.ifdesign.de



In 2009 Zumtobel won four iF Design Awards, including one for the Zbox lighting control system (top). The award ceremony in Hanover attracted numerous visitors and representatives of the press (bottom).



At the opening event, the renowned architect and artist Hani Rashid gave an introductory talk on the subject "Light and Art". Photo: Zumtobel

NEW LIGHTING CENTRE IN PRAGUE

Zumtobel have strengthened their commitment in central and eastern Europe and opened a new lighting centre in Prague. With more than 500m² metres of floor space, the showroom offers space for the application-oriented demonstration of new products and in-depth discussions with customers.

"The new lighting centre in Prague is not simply a showroom, it is our communication platform. Here we can present the most important products designed for different areas of application, as well as, the 'Humanergy Balance' philosophy behind their design in real applications", says Vladan Jesensky, Managing Director of Zumtobel Czech Republic and Slovakia. By setting up its own sales and advice locations worldwide, Zumtobel makes it possible for its customers to learn about the innovative product range and make use of the advisory expertise which is available locally, in the language of the country. With the opening of the new centre in Prague, Zumtobel currently has 14 lighting centres. The three lighting forums in Dornbirn, Lemgo and Vienna are even bigger and thus more prestigious. Nonetheless, all have one aim in common: they are intended to serve as networking and training platforms for both customers and employees. This is where the transfer of product- and application-specific knowledge takes place in the form of seminars and workshops. However, discussions with specialists regarding individual projects or outstanding exhibitions on architecture, design and technology are key elements in the dialogue with customers.

In total, 28,000 to 30,000 customers worldwide visit a Zumtobel lighting forum or lighting centre each year. This makes them part of an international network which lives and grows on the mutual exchange of ideas and personal vocational development.

www.zumtobel.com





CREATIVE LIGHTING AT ART BASEL IN MIAMI

At Art Basel in Miami, Zumtobel presented fascinating light solutions for art and culture. Zumtobel exhibited two unusual lighting systems in the Art Collectors Lounge at Art Basel Miami: the multifunctional lighting system Supersystem and the Vortexx chandelier, which was created from designs by the renowned architect Zaha Hadid.

Art Basel Miami is the most important art exhibition in America. 240 selected galleries from more than 30 countries are exhibiting paintings, drawings, sculptures, photographs, installations and videos. For the third time in a row, Zumtobel were also in attendance as part of this exclusive group, presenting fascinating lighting solutions for art and culture. Two unusual lighting systems were presented in the Art Collectors Lounge at Art Basel Miami: the Supersystem multifunctional lighting system and the Vortexx chandelier which was created from designs by the renowned architect Zaha Hadid.

The subject of lighting has increased significantly in importance in recent years. Its dimension as an experience, both architectural and aesthetic, plays an increasingly important, often decisive role: light is not simply for practical use, light doesn't simply fulfil functions, increasingly it is also used as an emotional medium. It creates moods, conveys subtle messages and in conjunction with space and architecture it displays a quite



Zumtobel's contribution to Art Basel Miami included the Vortexx chandelier by Zaha Hadid (large picture at top). Chinese artist and designer Ai Weiwei in the Art Collectors' Lounge (small picture at top). Photos: Zumtobel

unique creative force which creates aesthetic value. The right lighting, its skilful composition and control creates whole worlds of experience, and transforms buildings, both outside and in, into walk-in artworks.

For years, engaging with light, architecture and art has been both a profession and an exciting challenge for Zumtobel. Architects, lighting planners and artists are looking for the new, the unprecedented, for change and transformation. The way the effect of space is changed through light – with the aid of modern technologies and materials – plays a particularly important role here.

www.artbaselmiamibeach.com

SUCCESSFUL IN THE HEALTH CARE MARKET

With more than 2,500 exhibitors from over 65 countries around the world and more than 60,000 visitors, the health care trade fair Arab Health proves its importance, especially for the Middle East region. This year Zumtobel took part in this prestigious trade fair in Dubai for the fifth time. For the first time, the company was exhibiting at a joint stand together with the German company Völker, the market leader in hospital and care beds in Germany.

This proved to be a good decision, because over 20% more contacts were achieved than in the previous year. These contacts included, above all, investors, architects, planners, hospital operators and health authorities. This successful presence is also attributable to the exploitation of the two companies' synergies and networks. For example, it was possible to present nursing and care facilities as a complete application and thus show the customers an extensive, complementary range of products.

Representatives of the Health Ministries (MOH = Ministry of Health) of Saudi Arabia, the United Arab Emirates and Oman also visited the exhibition stand. Zumtobel are now looking forward to three major orders for hospitals in Saudi Arabia. One project was awarded directly at the trade fair itself, other order negotiations took place with decisionmakers at the fair and the orders are expected to be awarded shortly.

www.arabhealthonline.com



At Arab Health, Zumtobel shared a joint exhibition stand with the company Völker. An order for the equipment of hospitals was awarded directly at the trade fair. Photo: Zumtobel

MAKING DINING AN EXPERIENCE WITH LIGHT

Changing theme nights, surprising culinary creations and a multimedia mix of light, music and video show are intended to make a visit to the recently-opened restaurant Schramm's in Au in der Hallertau an experience for guests. In collaboration with Austrian interior designers Eder-dp and their clients, Manuela and Karsten Schramm, the Freising architectural practice Depisch Architekten created a modern restaurant from two buildings which were in need of renovation. The view from outside through the broad glass façade into the cheerfully lit bar invites visitors to enter.

Inside, the bar is decorated in warm wood tones, the room is enlivened through a novel lighting concept. Video-capable and fitted with LEDs, the Cielos modular lighting system welcomes guests with lighting effects such as passing clouds. In addition, a harmonious overall ambience is created by the LED-backlit alcoves. Planungsbüro Silberbauer were responsible for the tendering process and the implementation of the concept. Guests reach the restaurant on the first floor via an elliptical staircase in pure white. Illustrations hung on the walls, reflecting the evening's theme, are intended to put visitors in the right mood as they ascend to the restaurant. The stairs and pictures are artfully lit by Tempura LED spotlights. Those who enjoy a club style atmosphere can relax in the spacious lounge.

www.schramms.org



54 Tempura LED spotlights provide atmospheric illumination for the stairs leading to the restaurant (small picture at bottom). Dynamic lighting effects created from shifting patterns of colour on the Zumtobel Cielos LED wall create a unique feel-good atmosphere in the bar (large picture at bottom). Photos: Marcus Buck



Zaha Hadid's light sculpture Vortexx expressively represents water both as an element and as the main theme of the Museum of Water in St. Petersburg. Photo: Tochka Oporý

FLOWING LIGHT

Since its opening in August 2008, the Museum of Water in St. Petersburg has been one of the city's most highly-regarded buildings within the architecture and art scene. The renovation of the present museum building had been commissioned by the state-owned company "Water Channel", which is responsible for providing the water supply to the Russian metropolis.

The historical building dates from the beginning of the 19th century and served at the time as an underground water tank filter which purified the water, removing residues and making it drinkable. In the now fully-restored premises, particularly in the underground vaults, an impressive multimedia show provides the visitor with an insight into the most important properties of water.

In order to provide a relaxed and even general illumination in the entrance hall, the architects and designers chose the 2Light downlight system by Zumtobel. Using a successful combination of clear forms and high-quality materials, it provides a lively lighting effect arising from the exactly balanced ratio between the direct and diffuse lighting components. The Vortexx light sculpture designed by Zaha Hadid provides an additional highlight, expressively representing the element of water as the main theme of the museum: it seems as if the light sculpture were an eternally flowing band of light. With its continuously changing modulation of colours, the light almost looks like a column of water flowing down from the ceiling.

“By looking at light in a different way I want to create a reality, by evoking the state in which we find ourselves when we gaze into a fire and experience the not-thinking-in-words relationship with light.”

James Turrell

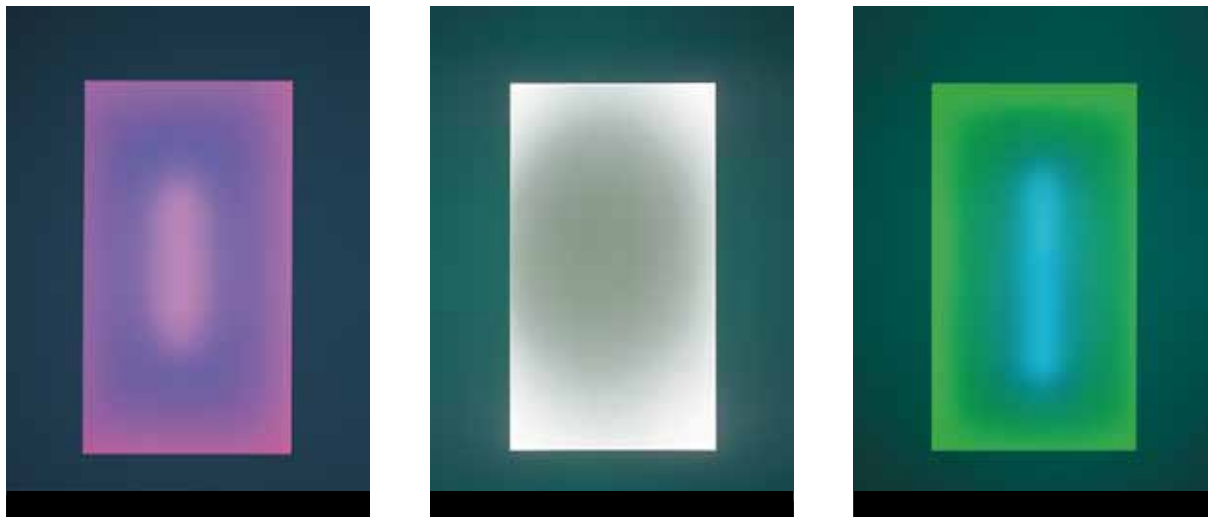

LEDS CONTROL

Fascinating LED lighting solutions –
dynamically and efficient

BUILT VISION

Dornier Museum für Luft- und Raumfahrt in Friedrichshafen
with light façade by James Turrell

AS FAR AS THE EYE CAN SEE

the Hotel Budersand on Sylt

GLOBAL REGIONAL

a ramble through the lighting forums and lighting centres

Imprint

LIGHTLIFE 2
Lighting Magazine by Zumtobel
10th year of publication
Spring 2009

Published by
Zumtobel Lighting GmbH
Schweizer Straße 30
6851 Dornbirn/A
Phone +43 5572 390-0
info@zumtobel.com
www.zumtobel.com

Responsible for Contents
Herbert Resch

Project Management
Kerstin Schitthelm
lightlife@zumtobel.com

Editorial office and Publisher
Institut für internationale
Architektur-Dokumentation
GmbH & Co. KG
Sonnenstraße 17
80331 Munich/D

Design Concept and Layout
Atelier Bernd Kuchenbeiser
Munich/D

Translations
Translation bureau
Antoinette Aichele-Platen
Munich/D

Coordination of photographs
Markus Deutschmann

Production
Lorenz Mayer-Kaup

Litho
Fitz Feingrafik

Printed by
Graphische Betriebe Eberl,
Immenstadt/D

Cover Photo
Danish Radio Concert Hall
Copenhagen/DK
Agnete Schlichtkrull

Photos p. 0, p. 3, p. 48
Zumtobel

Photo p. 2 top left
Bjarne Bergius Hermansen/DR

Project Team

Danish Radio Concert Hall,
Copenhagen/DK
Burkhard Ehnes
Zumtobel Licht GmbH
Burkhard.Ehnes@zumtobel.com
www.zumtobel.com

University Centre Tomáš Bata,
Zlín/CZ
Maletičová Marie
Zumtobel lighting. s.r.o.
Marie.Maleticova@zumtobel.com
www.zumtobel.cz

University of Warwick, Coventry/UK
James Coles
Zumtobel Lighting Ltd.
James.Coles@zumtobel.com
www.zumtobel.co.uk

Marienkrankehaus, Hamburg/D
Universitätsklinikum Hamburg-
Eppendorf/D
Andreas Fischer
Zumtobel Licht GmbH
Andreas.Fischer@zumtobel.com
www.zumtobel.de

T-Mobile Shop, Vienna/A
Markus Putzlager
Zumtobel Licht GmbH
Markus.Putzlager@zumtobel.com
www.zumtobel.at



Printed on chlorine-free paper from exemplary sustainable forestry.

The magazine and all articles contained are protected by copyright. May not be reproduced without prior permission of the publisher.

Editorial contributions and comments do not necessarily reflect the publisher's opinion.

If the creators of some photographs were not determined despite careful research, copyrights are nevertheless protected. The publisher should be notified if applicable.

Zumtobel Lighting Magazine subscription, suggestions or requests:
lightlife@zumtobel.com

LEDS CONTROL

